

Data	Rev.	Descrizione modifica	Autore	CDM

Autore S. Piccardo	Data 08/07/2010	Materiale (Material)	Finitura (Finish)	Peso (Weight) [Kg]
		Tabelle tolleranze di rif.	Denominazione (Title)	
		Form. A3	Scala	Codice (part number) PAVIMENTO
				Foglio 1 / 2

FRESATA PER RUOTA DI SUPPORTO DA EFFETTUARE SU ENTRAMBI I LATI

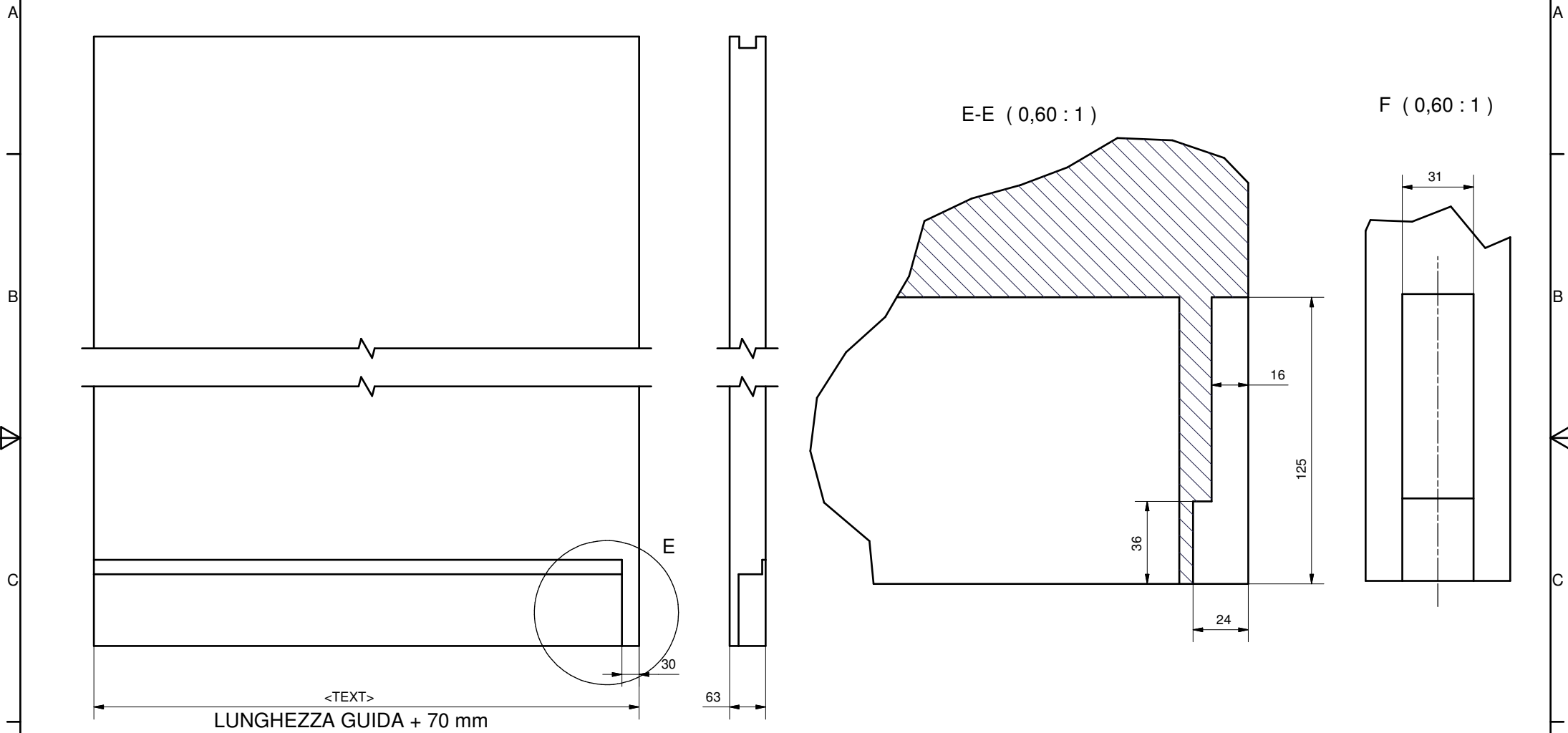

Data	Rev.	Descrizione modifica	Autore	CDM

Autore S. Piccardo	Data 08/07/2010	Materiale (Material) Al 6060 T5 (UNI 9006/1)	Finitura (Finish)	Peso (Weight) [Kg]
		Tabella tolleranze di rif.	Denominazione (Title)	
		Form. A3	Scala	Codice (part number) porta pavimento