

TWICE

ISTRUZIONI DI MONTAGGIO ASSEMBLY INSTRUCTIONS

MODELLO:
MODEL:

78.1480.25 TWICE

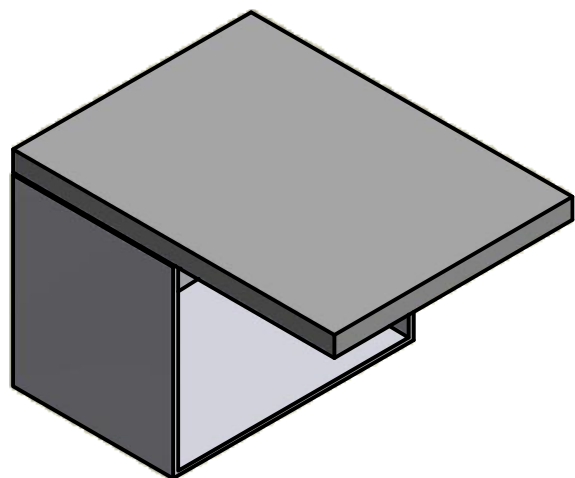

DIMENSIONI GENERALI GENERAL DIMENSIONS

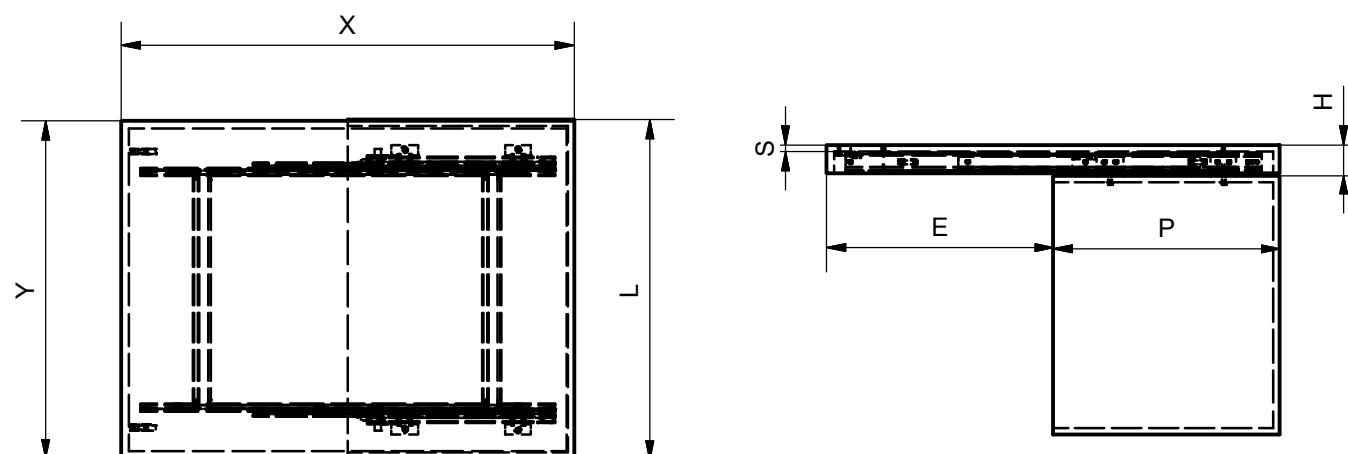

CODICE - CODE	P (mm)	L (mm)	E (mm)	Z (mm)	X (mm)	S min (mm)	H (mm)
78.1480.25	600	900	600	L-6	1200	18	80.5

CONTENUTO DELLA CONFEZIONE INCLUDED IN THE PACKAGING

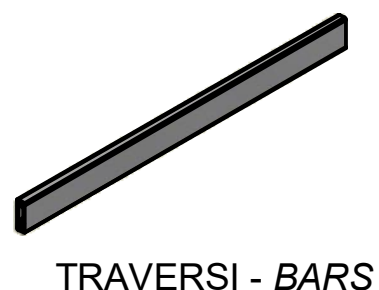

TRAVERSI - BARS

GUIDE - SLIDES

SACCHETTO ACCESSORI - ACCESSORIES

- A. Chiave esa. n.5 - n.5 Allen key
- B. Chiave esa. n.4 - n.4 Allen key
- C. Bussola M6 - M6 bush (x 4)
- D. Keku (x 2)
- E. Distanziale Keku - Keku spacer (x 2)
- F. Rondella - Washer (x 4)
- G. Vite legno 3.5x16 - 3.5x16 FHP screw (x 4)
- H. Vite TCCE M6x12 - M6x12 SHCS screw (x 8)
- I. Vite TCCE M6x40/75 - M6x40/75 SHCS screw (x 4)
- J. Vite TCB M6x60 - M6x60 BHCS screw (x 4)

SEQUENZA DI FUNZIONAMENTO FUNCTIONING STEPS

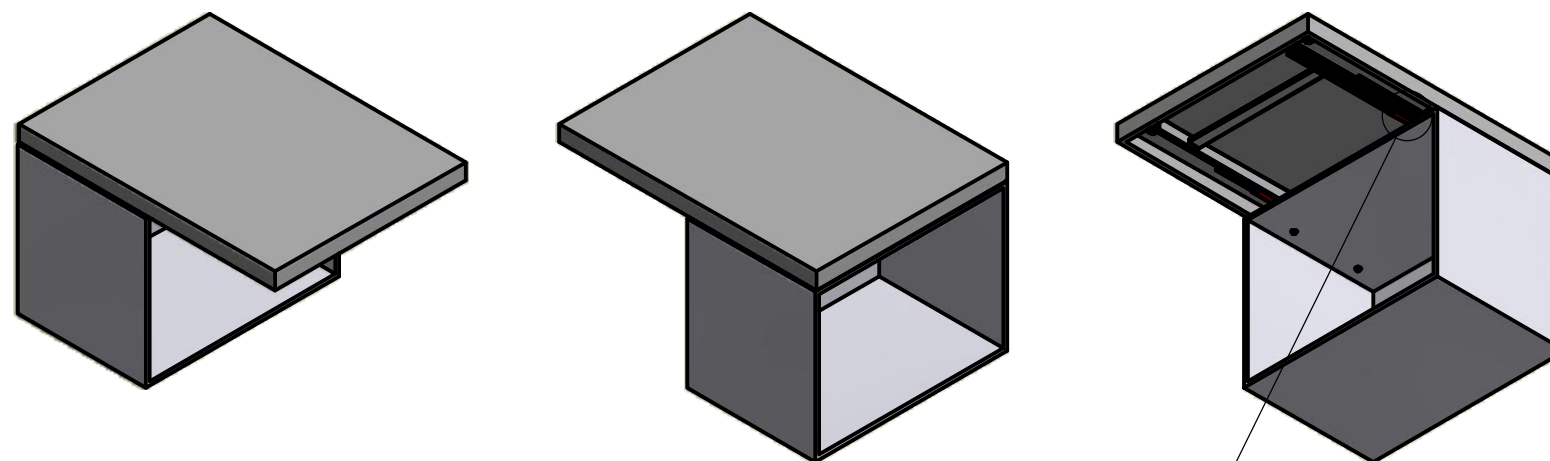

PER CHIUDERE IL MECCANISMO
SPINGERE LE DUE LEVE ROSSE IN
PLASTICA VERSO L'INTERNO
TO CLOSE THE MECHANISM PUSH
TOWARD THE INSIDE THE TWO RED
PLASTIC PARTS

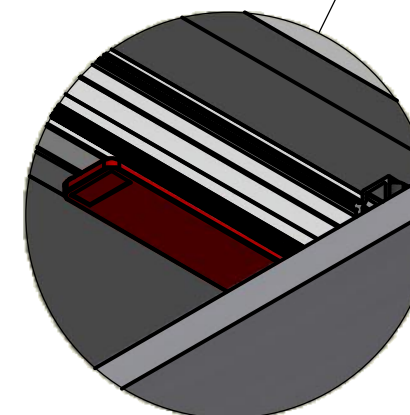

POSIZIONE FORI / DIMENSIONE PIANI

HOLES POSITION / SIZES TOPS

MONTAGGIO DEL MECCANISMO

MOUNTING OF THE MECHANISM

VISTA DALL'ALTO - TOP VIEW

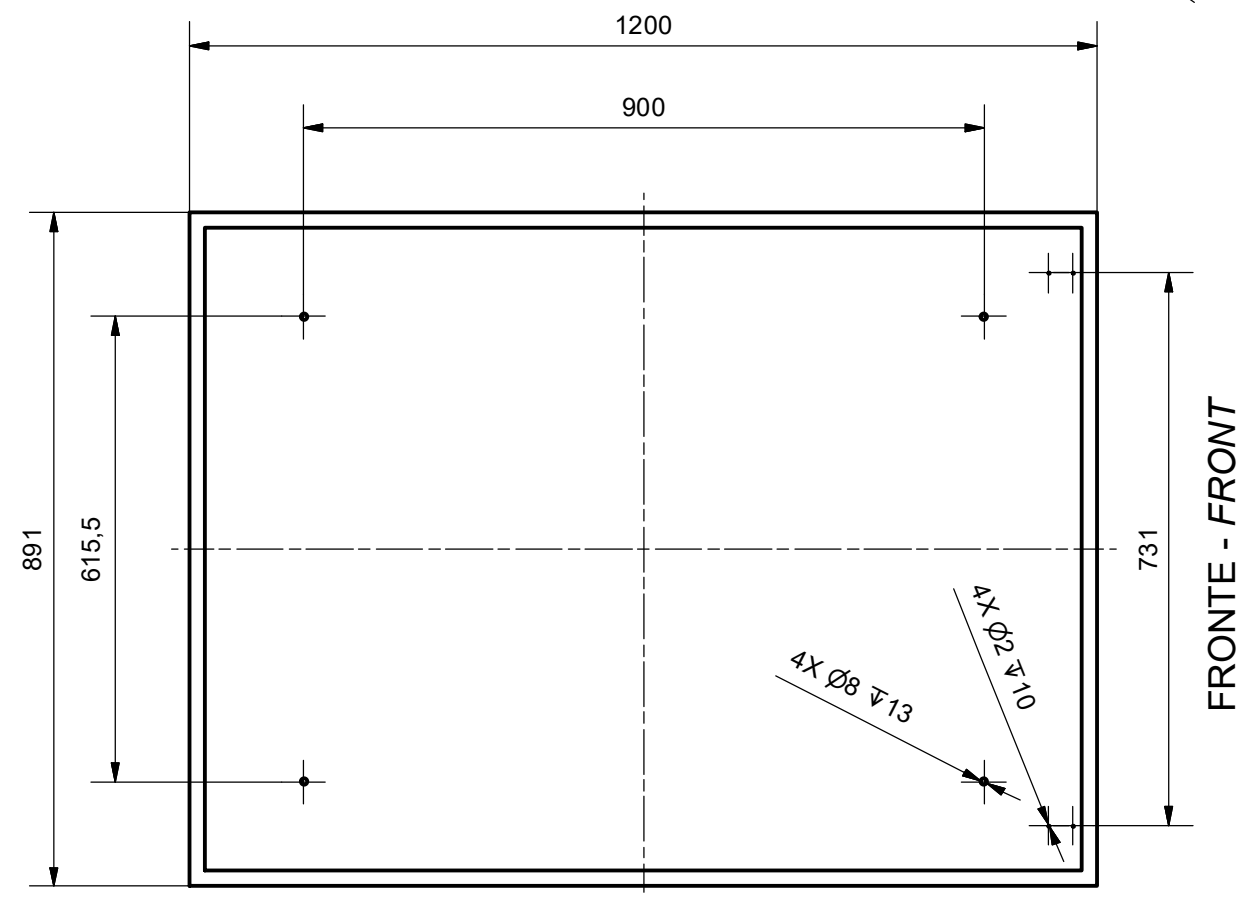
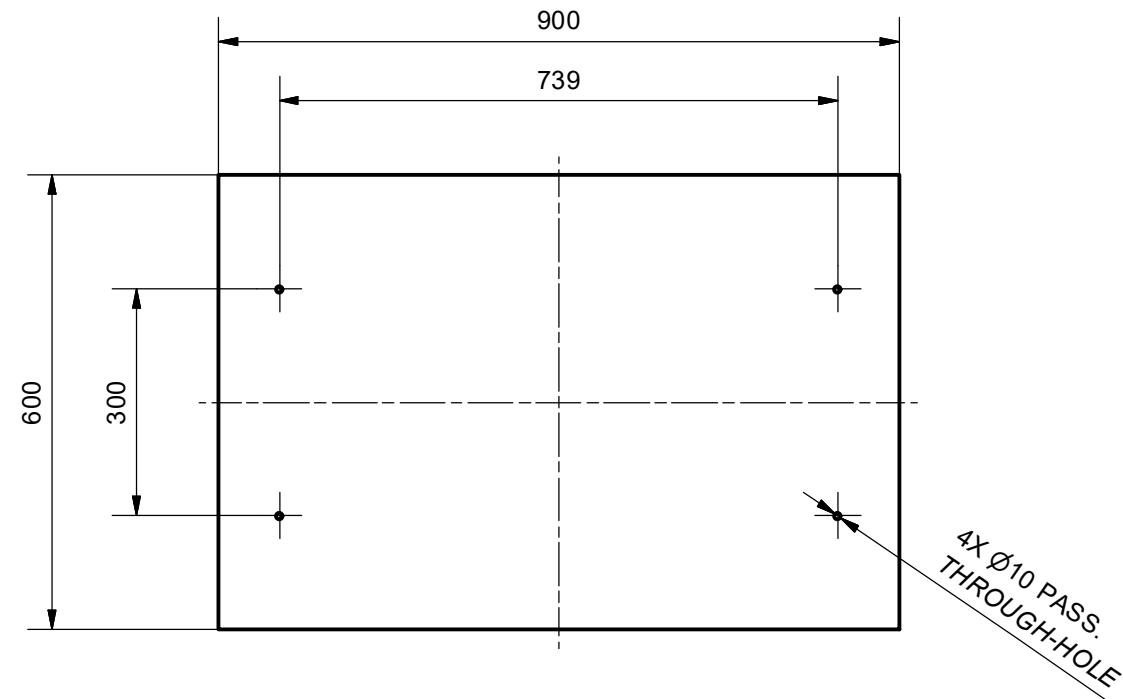

C. Bussola M6 - M6 bush (x 6)

VISTA DAL BASSO - BOTTOM VIEW

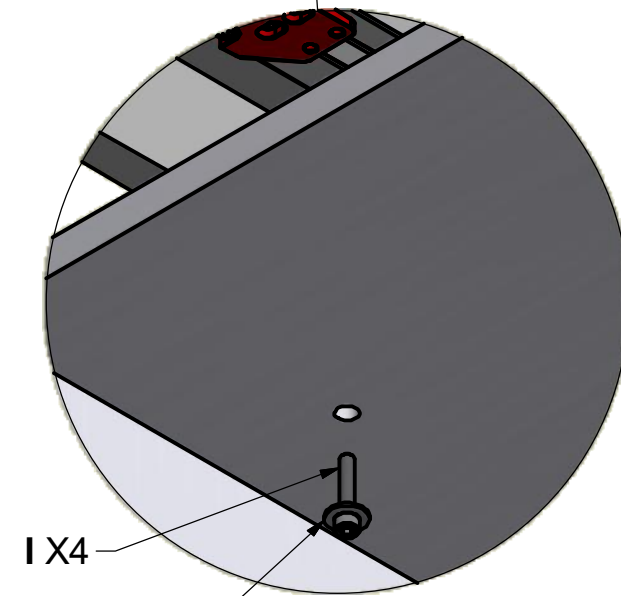
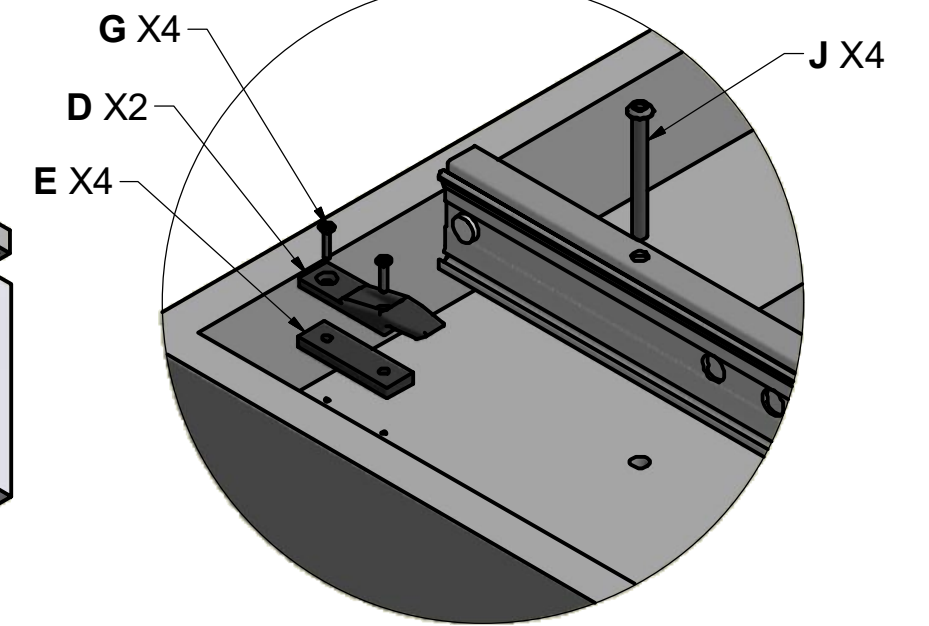
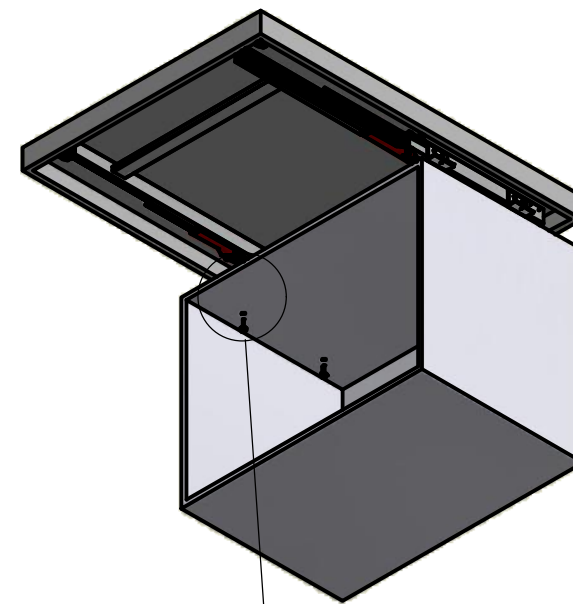

SACCHETTO ACCESSORI - ACCESSORIES

- A. Chiave esa. n.5 - n.5 Allen key
- B. Chiave esa. n.4 - n.4 Allen key
- C. Bussola M6 - M6 bush (x 4)
- D. Keku (x 2)
- E. Distanziale Keku - Keku spacer (x 2)
- F. Rondella - Washer (x 4)
- G. Vite legno 3.5x16 - 3.5x16 FHP screw (x 4)
- H. Vite TCCE M6x12 - M6x12 SHCS screw (x 8)
- I. Vite TCCE M6x40/75 - M6x40/75 SHCS screw (x 4)
- J. Vite TCB M6x60 - M6x60 BHCS screw (x 4)